	<p>Title: MARSHALL SKATE PARK IMPROVEMENT PROPOSAL</p>			
<p>Your Scene Is Only As Lamé As You Are</p>	<p>Author: G. Klein</p>	<p>Issue Date: 7.6.2010</p>	<p>Doc. No: MSC-1</p>	
	<p>Approval: YSIOALAYA</p>	<p>Rev. Date: 7.6.2010</p>	<p>Rev. No. 1</p>	<p>Page 1/3</p>

1. PURPOSE

This document shall inform the appropriate parties within the City of Marshall with details about the non-profit organization, Your Scene Is Only As Lamé As You Are (YSIOALAYA) and plans to improve the community skate park.

YSIOALAYA is a non-profit organization formed in the spring of 2010 with the sole intention of making improvements to the existing community skate park and the greater Ketchum Park Area. The intention is to privately raise funds and work with local businesses and licensed contractors, along with volunteers, to procure and professionally install new equipment that will enable skatepark users (local and visiting) to grow with their skill level and instill a sense of ownership and pride. The group consists of the following members:

- Gipp Klein, President
- Matt Huggett, Secretary
- Aaron Morse, Treasurer
- Travis Dopp
- Aaron Newsome

2. SCOPE

The scope of this project is to communicate desired improvements to complete at the community skate park. Our intention is to integrate feedback from the people who utilize the park with requirements specified in the American Society for Testing Materials Standard F 2334 – 09 Standard Guide for Above Ground Public Use Skatepark Facilities (ASTM F2334-09).

3. DEFINITIONS

No definitions at the current time.

4. GENERAL

The current skatepark consists of a fenced in 90-foot by 120-foot concrete slab equipped with portable elements including two 4-foot x 8-foot half pipes, a modular hip to flat obstacle with a fixed hand rail, a 2-foot by 4-foot fun box and a picnic table.

The existing location is acceptable from an access standpoint, but lends itself to undergo both equipment and area improvements to create connectivity with the rest of Ketchum Park area.

IMPORTANT NOTICE: This is a CONTROLLED DOCUMENT.

A hard copy may not be the document currently in effect. The current version is always on the CLYDEUNION Intranet.

	<p>Title: MARSHALL SKATE PARK IMPROVEMENT PROPOSAL</p>			
<p>Your Scene Is Only As Lame As You Are</p>	<p>Author: G. Klein</p>	<p>Issue Date: 7.6.2010</p>	<p>Doc. No: MSC-1</p>	
	<p>Approval: YSIOALAYA</p>	<p>Rev. Date: 7.6.2010</p>	<p>Rev. No. 1</p>	<p>Page 2/3</p>

Our goal is to raise money to not just benefit the park, but to improve the physical appearance, improve security and ensure that adequate rest rooms are provided for the area.

5. PROPOSAL

Our formalized plan consists of the following:

- Raise money from private equity to utilize for improvements. Preliminary goal is \$20,000 dollars by 9/30/2010;
- Procure ASTM F 2334 – 09 compliant ramp & equipment plans along with pre-fabricated, engineered transitions. This would occur in alignment with fund raising. See provided examples of ramp plans purchased from Whitefish Ramps;
- Construct and oversee installation of equipment in the existing community skatepark utilizing licensed & insured construction professionals along with volunteers. Desired timing would be Fall of 2010 or Spring of 2011. Note that proposed layout of equipment is included as Attachment A.;
- Construction materials to consist of marine-grade lumber top coated with engineered decking material such as skatelite®, etc. for weather and noise reduction purposes. Note that pre-engineered transitions are non-marine lumber.
- Assumed maximum height proposed not to exceed 6-feet;
- In conjunction with pending application for Adopt-A-Parks program, develop and complete required equipment inspections and area improvements (weeding, etc);
- Work to align ourselves with the groups responsible for Kids Kingdom and other groups desiring to improve landscaping to help facilitate park improvements.
- Develop Phase II of improvements to raise funds for and integrate area expansion, 2011-2012
- Integrate our group to fill the seats of the currently vacant Marshall Skate Park Committee, working in conjunction with the Recreation Department as necessary.

The proposed layout lends itself to safety and flow in the park. This configuration provides a “constant movement” versus existing layout.

6. REFERENCES AND RELATED STANDARDS

ASTM F 2334 – 09 Standard Guide for Above Ground Public Use Skatepark Facilities

IMPORTANT NOTICE: This is a CONTROLLED DOCUMENT.

A hard copy may not be the document currently in effect. The current version is always on the CLYDEUNION Intranet.

	Title: MARSHALL SKATE PARK IMPROVEMENT PROPOSAL			
	Your Scene Is Only As Lamé As You Are	Author: G. Klein	Issue Date: 7.6.2010	Doc. No: MSC-1
	Approval: YSIOALAYA	Rev. Date: 7.6.2010	Rev. No. 1	Page 3/3

Attachment A
Proposed Park Layout

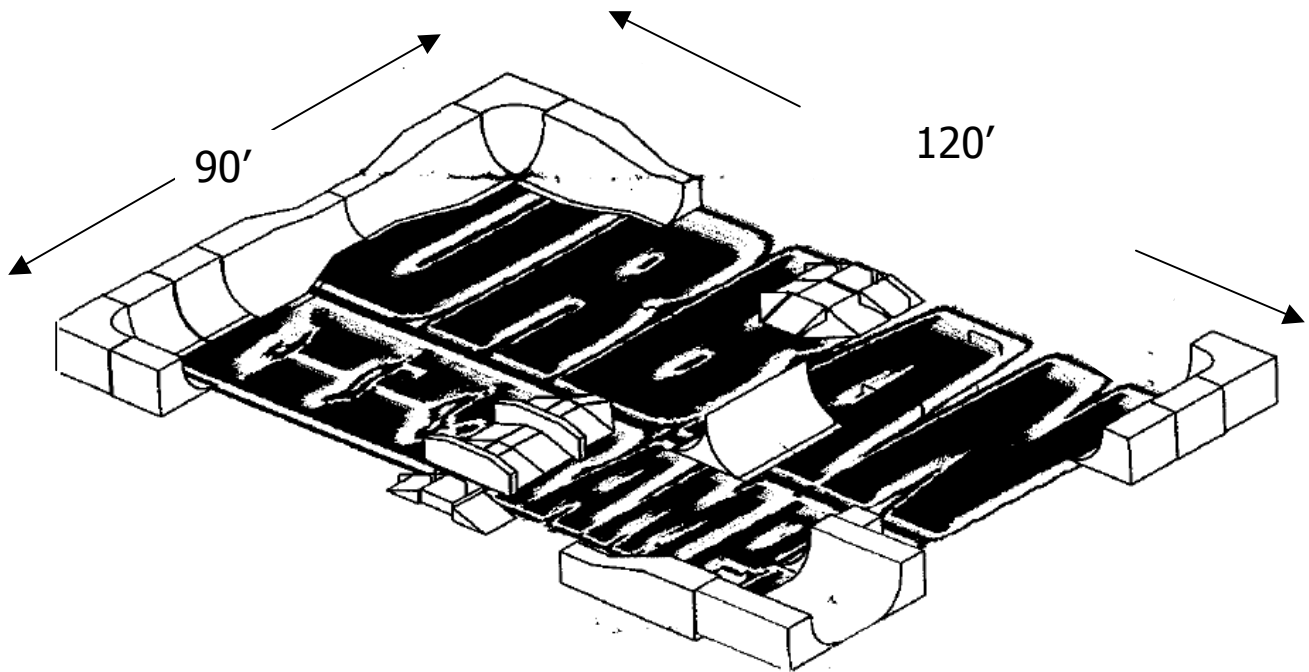

*Note that the proposed plan would not interrupt current infrastructure such as fencing or extend beyond currently defined area. May require moving an entrance point, etc.